

S-Quad Sensor and Sensor Sounder

A truly intelligent analogue sensor combining local processing in the sensor and the panel to achieve an immediate response to real fires whilst minimising the risk of false alarms.



Description

A comprehensive range combining sensor sounder and voice in one multifunctional device.

KEY FEATURES

- Complete range of sensors with combinations of advanced sensing technologies including heat, dual angle optical scatter and carbon monoxide (CO)
- Combined sensing of carbon monoxide with dual angle optical scatter and heat allows a higher level of false alarm immunity in presence of steam and while still maintaining the integrity of detecting fires
- Each sensor has certified sensitivity settings that suit certain environments/ applications and may be programmed for different times of the day if required
- Short circuit Isolator in each device
- Configurable input/ output connection for remote indicator or supervisory input fully synchronised sound patterns via the control panel
- Sensor sounders have adjustable sound level and tones to match system sounders
- Sounder element monitoring and over-load protection to ensure operation even in event of cable fault
- Sound output synchronised and compatible with S-Quad range of EN54-23 VADs

S-Quad Sensor and Sensor Sounder Technical Specifications

Dimensions (mm)

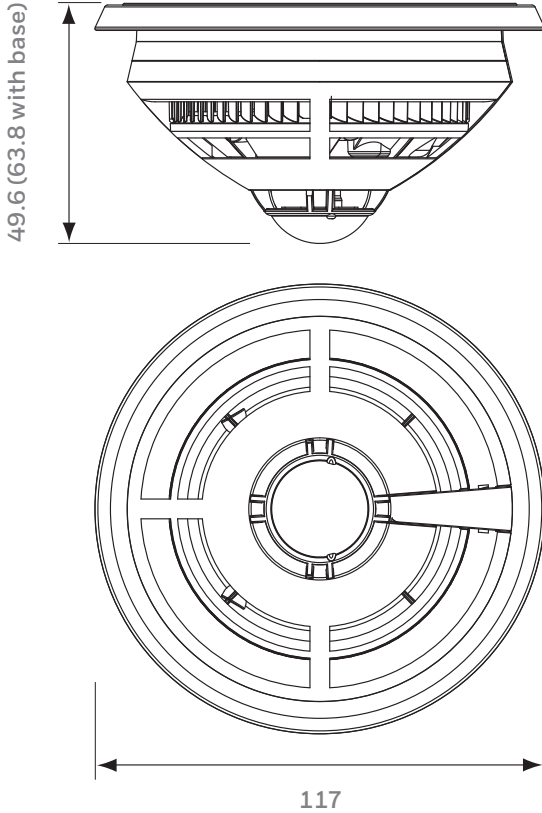

SPECIFICATION	
OPERATING TEMPERATURE	-10 to +50°C
WEIGHT	0.11kg (0.17kg inc Base)
DEVICE / LOOP LOADING	200 devices per Loop (assumes 800mA Loop Card)
COLOUR	White RAL 9010
	Black RAL 9005

APPROVALS	SENSOR ONLY	SENSOR SOUNDER	
SENSOR TECHNOLOGY	Heat	EN54-5	EN54-3
	Optical	EN54-7	N/A
	Optical Heat	EN54-5, EN54-7, EN54-17, EN54-18	EN54-3
	Dual Optical Heat	EN54-5, EN54-7, EN54-17, EN54-18	EN54-3
	Dual Optical Heat & CO	EN54-5, EN54-7, EN54-17, EN54-18	EN54-3

PART CODES S-QUAD SENSORS AND SENSOR SOUNDRERS		
SENSOR BASES	S4-700	Sensor Base - (White)
	S4BK-700	Sensor Base - (Black)
SENSORS	S4-720	Heat Sensor (White)
	S4-715	Optical Sensor (White)
	S4-710	Optical Heat Sensor (White)
	S4-711	Dual Optical Heat Sensor (White)
	S4BK-711	Dual Optical Heat Sensor (Black)
	S4-901	Dual Optical Heat and Carbon Monoxide Sensor (White)
SENSOR SOUNDRERS	S4-780-S	Heat Sensor Sounder
	S4-770-S	Optical Heat Sensor Sounder (White)
	S4-771-S	Dual Optical Heat Sensor Sounder (White)
	S4-711-V	Dual Optical Heat Voice Sensor Sounder (White)
	S4BK-711-V	Dual Optical Heat Voice Sensor Sounder (Black)