

# STI Universal Stopper<sup>®</sup>



## PRODUCT OVERVIEW

These indoor and outdoor low profile or dome polycarbonate covers protect devices such as manual call points, emergency buttons and dual action pull stations etc., without restricting legitimate operation. The versatile cover offers excellent protection against physical damage (both accidental and intentional), dust and grime as well as severe environments inside and out.

## IMPORTANT NOTICE

When used on fire systems, Universal Stopper is intended for areas where the incidence of false fire alarms from manual call points is high or has proven to be a serious problem. Any disadvantage of the device is more than balanced when one considers the consequences of false fire alarms, especially if fire service personnel and equipment are responding to a false fire alarm when they are needed for a real fire somewhere else. Add to this the disruption to the facility when false alarms occur. If you have, or may have, a problem with false fire alarms or physical/weather damage to your fire alarm activation devices, the Universal Stopper could prove invaluable.

## KEY FEATURES

### General Information

- These indoor and outdoor low profile or dome polycarbonate covers can protect a variety of devices without restricting legitimate operation.
- Three year guarantee against breakage of polycarbonate in normal use (one year on electromechanical and electronic components).

### Design

- Prevents false alarms, without hindering legitimate operation of a manual call point in the event of an emergency.

### Construction

- Tough polycarbonate housing can withstand severest of knocks.

### Installation

- A simple 4 fixing installation can retrofit over existing device.
- Can accommodate flush or surface mount applications.
- Typical working properties of polycarbonate are -40° to 121°C (-40° to 250°F).

### Electronics

- Available with or without a 96 dB integral sounder, powered by a 9V PP3 battery. The sounder draws immediate attention to the area.
- Optional 12-24 VDC powered units.

### Options

- One breakseal is supplied with each model. Additional breakseals are available for added security.
- Available in a range of colours.
- Custom labelling available.

# STI Universal Stopper®

Dimensions and Technical Information

## BUILD YOUR OWN MODEL



**Cover Options:**  
 3 = Dome cover  
 4 = Low profile cover

**Mounting Options:**  
 0 = Flush Mount (Open backed) - IP54  
 1 = Surface Mount - Clear Spacer (Dual Mount - Open backed) - IP54  
 6 = European Enclosed Back Box, 20mm Thread Point & Sealed Mounting Plate - IP66  
 7 = European Enclosed Back Box, 20mm Thread Point & Open Mounting Plate - IP56

**Hood/Horn Options:**  
 00 = No Label hood  
 10 = Label hood without sounder ★  
 20 = Label hood with sounder ★●  
 30 = Label hood with sounder and relay ★●  
 ★ All colours except NC ● Not available with Low profile covers

**Housing/Sounder Colour & Label Options:**  
**FR** (red) - IN CASE OF FIRE - LIFT COVER / ACTIVATE FIRE ALARM  
**FR-BREAK** (red) - IN CASE OF FIRE - LIFT COVER / BREAK GLASS  
**FR-PULL** (red) - IN CASE OF FIRE - LIFT COVER / PULL FIRE ALARM  
**EG** (green) - IN CASE OF EMERGENCY - LIFT COVER / BREAK GLASS TO OPEN DOOR

<b>No Label</b>	<b>Custom Label</b>	For custom label option, must provide wording (2 lines, 30 characters per line including spaces limit)
NB = Blue	CB = Blue	
NC = Clear	CG = Green	
NG = Green	CR = Red	
NR = Red	CW = White	
NW = White	CY = Yellow	
NY = Yellow		

**Language Options:**  
 -FR French -NL Dutch  
 -ES Spanish -DE German  
 No additional coding is required for an English label

## MODELS AVAILABLE

- STI-13010FR** Universal Stopper, (flush mounted, dome cover with open back) without sounder, with ACTIVATE FIRE ALARM label
- STI-13120EG** Universal Stopper, (surface mounted, dome cover with open back) with sounder, with emergency exit label

**PLEASE REFER TO BUILD YOUR OWN MODEL TO GENERATE OVER 500 VARIATIONS OF THIS PRODUCT**

### ACCESSORIES:

- STI-1331** 37mm Spacer
- KIT-319** Remote Wiring Harness for Remote Power
- KIT-EA135** Servicing Pin
- STI-1314** Universal Stopper Backplate (U.S installation only)
- STI-6602** Replacement Sounder Unit
- STI/BS** Break Seals (Quantity. 10)
- KIT-M06540** Replacement Housing Shell (Red)  
 Add -G for Green, -B for Blue, -Y for Yellow, -K for Black, -W for White

## DIMENSIONS:

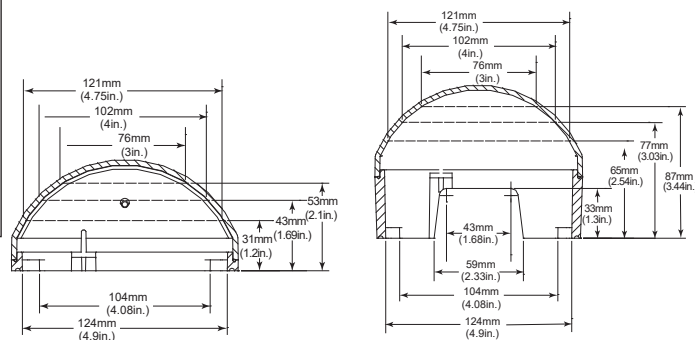

Flush Mount

Surface Mount

## EXTERNAL DIMENSIONS (mm):

Mounting Option	Height	Width	Depth
Flush	207	137	68
Surface	207	137	105
Enclosed Flush Back Box	207	137	71
Enclosed Back Box	207	137	102

## APPROVALS

TESTED AND APPROVED OR LISTED BY:  
 · UL/cUL Listed No. S2466

NB: When installed correctly, mounting options 0 and 1 are designed to meet the requirements of IP54. Mounting option 6 meets the requirements of IP66, and mounting option 7 meets the requirements of IP56.

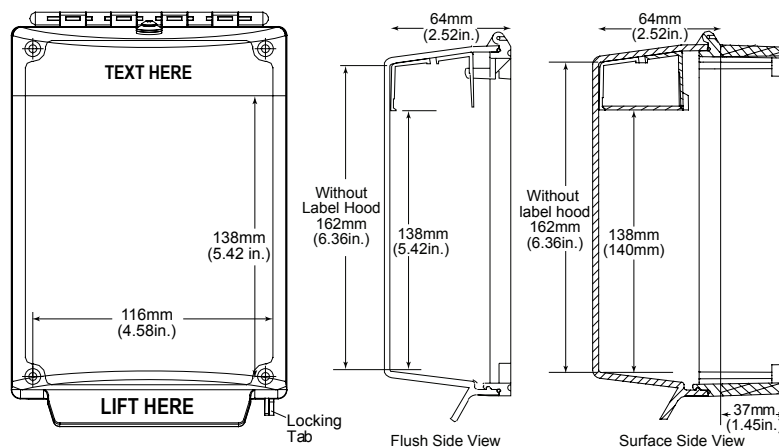

Locking Tab

Flush Side View

Surface Side View