

M700 Addressable Call Points

Data Sheet

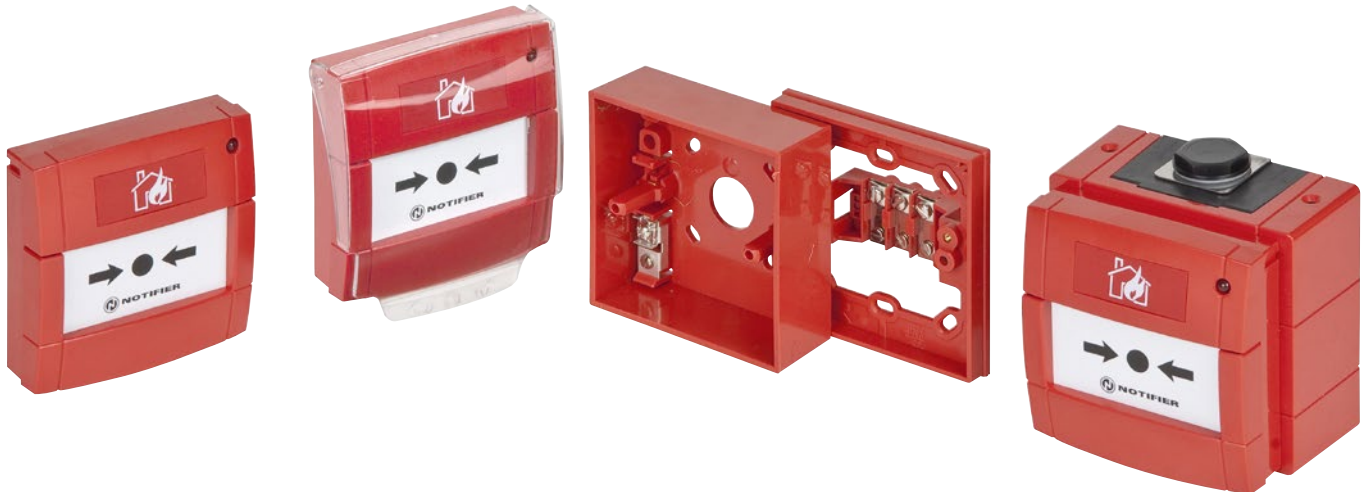

The M700 series with integral isolator, are call points designed to provide a manual alarm interface to NOTIFIER's fire alarm control panel.

Installation efficiency, flexibility and compliance with the latest standards are at the heart of the call point range.

Features

- Unique 'Plug & Play' installation concept
- Integral loop isolation
- Model available protected to IP67
- Re-settable operating element option
- Analogue addressable communications
- Semi-Flush or surface mounting
- Fully compliant with EN54, Part 11
- Backward compatibility
- Integral LED

The unique 'plug and play' concept is designed specifically to reduce installation time by using a terminal block which can be wired during the initial installation cabling with a link (P102) to provide continuity for testing. During the commissioning phase, the links are removed and the terminal block is simply inserted into the connector at the back of the unit. No re-termination is required.

Both break glass, supplied, and re-settable operating elements (PS230) can be used in the standard unit. Operation of the re-settable element, as well as being indicated by the units LED, is also indicated by a yellow strip on the element which becomes visible when activated. With the addition of a hinged transparent cover (PS200) the element may be protected against accidental operation and may be further protected by using a cover seal (PS056) which requires breaking in order to operate the unit.

The call points use one of 99 possible addresses which is simply 'dialled in' using the two rotary decade switches on the rear of the unit.

A specialist test key may be inserted into the bottom of the unit to lower the glass and release the micro-switch and thus a full functional test is achieved.

Installation

The call points are suitable for semi-flush mounting as standard, for indoor use. This uses a single-gang electrical knock-out box in conjunction with a terminal tray (ETT-P) for isolated screen continuity connection. However if surface mounting is required, then a matching single terminal back box is also available (SR1T).

Mounting hardware and installation instructions are provided with each module.

Addressable Manual Call Point M700KACI-FG

The M700KACI-FG with integral isolator, is a call point designed to provide a manual alarm interface to NOTIFIER's fire alarm control panel.

Installation efficiency, flexibility and compliance with the latest standards are at the heart of the call point range. The unique 'plug and play' concept is designed specifically to reduce installation time by using a terminal block which can be wired during the initial installation cabling with a link (P102) to provide continuity for testing. During the commissioning phase, the links are removed and the terminal block is simply inserted into the connector at the back of the unit. No re-termination is required.



Specifications

Addressable Manual Call Point M700KACI-FG (Glass) & M700KACI-FF (flexible Element)

Mechanical Specification

- Dimensions:

Semi-flush mounting:	
Height:	93 mm
Width:	89 mm
Depth:	27.5 mm
Surface mounting:	
Height:	93 mm
Width:	89 mm
Depth:	59.5 mm
- Weight:

Flush	110 g
Surface	130 g

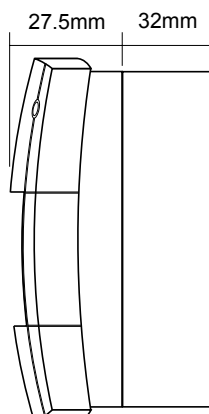
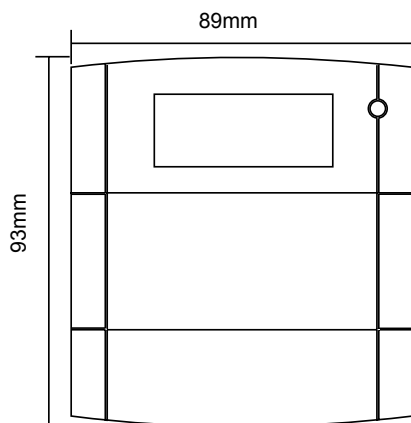

Electrical Specification

- Current Consumption

Quiescent:	360µA
Alarm Current:	6mA
- Operating Voltage: 15 V to 30VDC maximum

Environmental Specifications

- Operating temperature: -30°C to +70°C
- Relative humidity: 0% to 95%, non-condensing
- Ingress Protection (IP) Rating: IP24D

Addressable Waterproof Call Point M700WCP

This IP67 rated call point is available with integral isolator and designed to provide a manual alarm interface to Notifier fire alarm control panels where additional protection against the environment is necessary.

Installation efficiency, flexibility and compliance with the latest standards are at the heart of the call point range.

The unique 'plug and play' concept is designed specifically to reduce installation time by using a terminal block which can be wired during the initial installation cabling with a link (P102) to provide loop continuity for testing. During the commissioning phase, the links are removed and the terminal block is simply inserted into the connector at the back of the unit. No re-termination is required.



Specifications

Addressable Waterproof Call Point M700WCP-R//SG

Mechanical Specification

- Dimensions:
 - Height: 93 mm
 - Width: 97.5 mm
 - Depth: 71 mm
- Weight: 400 g (incl packaging)
- Mounting hole centres: 60mm

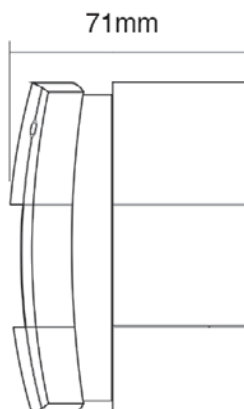
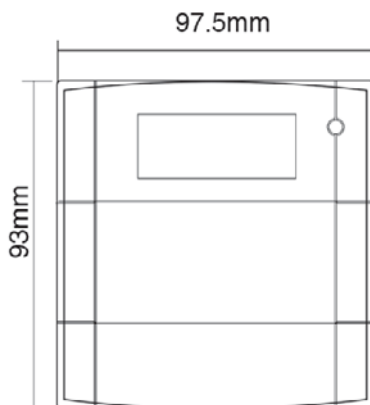









Electrical Specification

- Quiescent (with isolator): 360µA
- Alarm Current: 6mA
- Operating Voltage: 15 V to 30VDC maximum

Environmental Specifications

- Operating temperature: -30°C to +70°C
- Storage temperature: -30°C to +70°C
- Relative humidity: 0% to 95%, non-condensing
- Ingress Protection (IP) Rating: IP67

Product Range at a Glance

		Part Number
	Addressable call point with in built isolator. Glass included. Requires SR1T for surface mounting, terminal tray ETT-P and single gang back box for semi flush mounting.	M700KACI-FG
	Addressable call point with in built isolator. Flexible element included. Requires SR1T for surface mounting, terminal tray ETT-P and single gang back box for semi flush mounting.	M700KACI-FF
	Intelligent water resistant call point with isolator. Supplied with glass	M700WCP-R/I/SG
	Semi-flush mounting call point terminal tray.	ETT-P
	Surface mounting call point back box.	SR1T
	Transparent hinged cover.	PS200
	Call point cover seal (anti-tamper). Pack of 5.	PS056
	Pack of 10 EN54 Pt.11 glasses.	KG1/N10/GL1293
	Pack of 10 resettable elements.	PS230
	Pack of 10 continuity links.	P102