

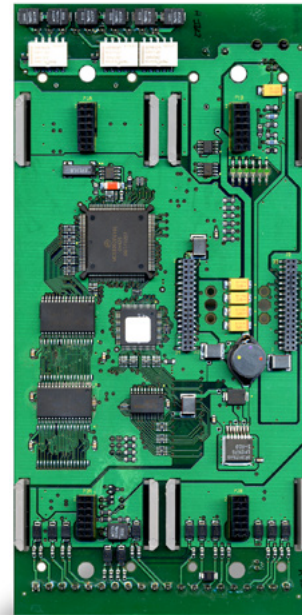

LIFE SAFETY & INCIDENT MANAGEMENT

EST3 Central Processor Unit

3-CPU3, 3-RS485A, 3-RS485B,
3-RS232



S3000

7165-1657:
0186

EN 54-2: 1997 + A1: 2006

EN 54-4: 1997 + A1: 2002 + A2: 2006

EN 54-16: 2008

Overview

The 3-CPU3 is the Central Processing Unit Module monitoring the status of all modules and providing the link for network communications. Although each local rail card contains their own micro-processor, the 3-CPU3 provides all inter-module communication and has the ability to download rail module operating parameters. Upon power up the 3-CPU3 automatically learns all local rail module attributes and locations. Site specific software is loaded into the 3-CPU3 which then downloads data to each local rail module. Firmware upgrades are also done from the 3-CPU3 eliminating the need to unplug chips on rail modules.

Mounting must be in the first two local rail spaces of the upper 3-CHAS7 (module chassis). Options for the 3-CPU3 include the addition of an LCD display and User Interface, RS-232 Communication Card, and RS-485 Series Network Communication Cards.

The 3-CPU3 is fully compatible on the same network with the 3-CPU and 3-CPU1 modules.

Standard Features

- Up to 1,000 history events
- RS-485 local rail communications
- Multiplexed audio channels
- Network communication media can consist of twisted copper RS485, short-haul modems and/or single or multimode fiber optic cables
- RS-232 communication card
- Form 'C' contacts for: Alarm, Supervisory and Trouble
- Low voltage memory write protection
- Non-volatile memory



الاتحاد لأنظمة اطفاء الحريق والحماية
UNION FIRE PROTECTION

Application

The 3-CPU3 helps make EST3 an extremely powerful and flexible system. As a single node, stand alone system a single 3-CPU3 controls 1 to 19 additional local rail modules. For larger systems, up to 64 nodes interconnect on a peer-to-peer multi-priority token ring protocol network.

The 3-CPU3 controls all local panel responses to automatic, user initiated, or network reported events. As a network node, it is an equal among peers, there is no master on the network. This gives exceptional response times over the network, less than three seconds.

Each 3-CPU3 provides slots at the back for mounting Network, and RS-232, cards. Removable terminal blocks on the 3-CPU3 support connection of network and audio data wiring. On board common relays also terminate at the 3-CPU3 terminals. To aid in trouble shooting and service, status LEDs monitor local rail, network, RS232 and audio data communications.

The **Network Communications** card mounts to the back of the Central Processor Unit. The 3-RS485A card provides a Class A, Class X or Class B circuit for network communications signals and support for a Class B, Class A or Class X circuit for the digitized audio signals. The 3-RS485B card provides a Class B, Class A or Class X circuit for network communications signals and a second Class B circuit for the digitized audio signals. The 3-RS485B card provides a Class B or Class A circuit for network communications signals and a second Class B circuit for the digitized audio signals. Network messages received by the Network Communications card are re-transmitted to the next network node. Re-transmission maximizes the wire run lengths between nodes. With 64 nodes miles of network length is possible. Fail safe mechanisms built into the card direct connect the data input and output ports should the network card or its related Central Processor fail. Network communications may be configured via copper or fiber media using the 3-FIBMB.

The **3-RS232 Communication Card** mounts to the back of the 3-CPU3. The 3-RS232 has two optically isolated RS-232 ports. The ports support connection of a printer and/or an external command center. Entire network downloading from one location (to all 64 nodes) is available through the RS-232 card.

Engineering Specification

It must be possible to support a single stand alone node or up to 64 nodes communicating on a peer-to-peer token ring protocol network. Network and digitized audio wiring shall be run in a [choose one: Class A, Class X or Class B] configuration. Network alarm response from alarm input to signal activation must be under 3 seconds. All field wiring must be to removable terminal blocks. Status LEDs must be provided for communications of network and internal rail communications. Inter-node communication speed must be programmable. Internal rail communications speed must be programmable.

Installation and Mounting

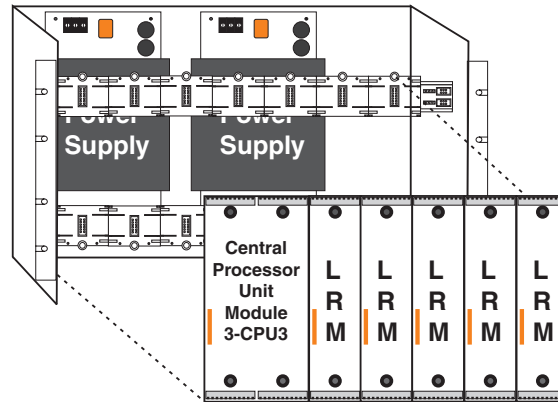

Data

Maximum resistance between any 3 panels	90 Ohms
Maximum capacitance between any 3 panels	0.3 μ F
Maximum distance between any 3 panels via RS485	5,000 ft. (1,524 m)

Capacitance, entire network

Maximum Accumulative Capacitance

Wire Size	38.4K Baud	19.2K Baud
18 AWG	1.4 μ F	2.8 μ F
16 AWG	1.8 μ F	3.6 μ F
14 AWG	2.1 μ F	4.2 μ F

Audio

Maximum resistance between any 3 panels	90 Ohms
Maximum capacitance between any 3 panels	0.09 μ F
Maximum distance between any 3 panels via copper RS485	5,000 ft. (1,524 m)



الاتحاد لأنظمة اطفاء الحريق والحماية
UNION FIRE PROTECTION

Typical Wiring

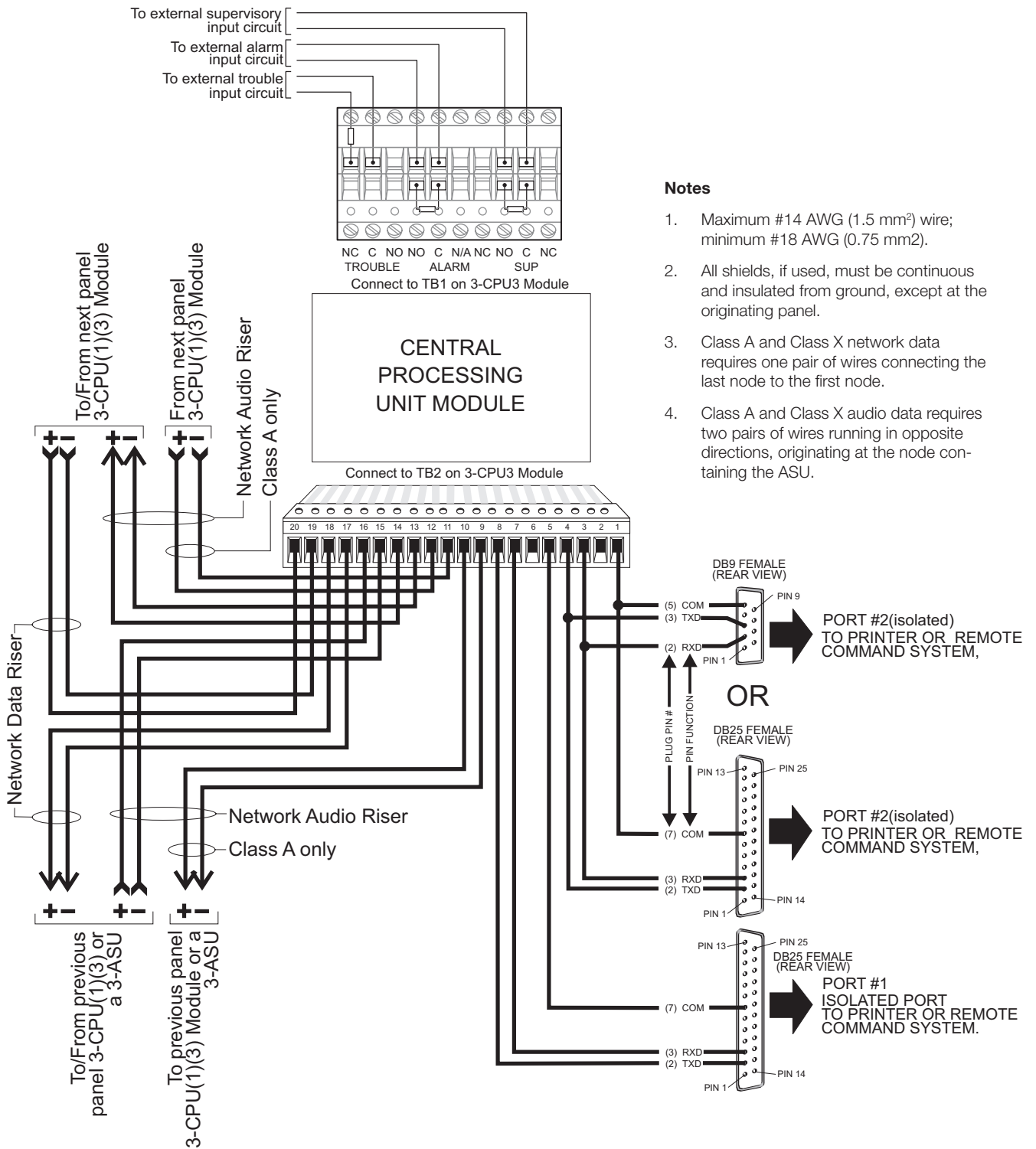

Notes

1. Maximum #14 AWG (1.5 mm²) wire; minimum #18 AWG (0.75 mm²).
2. All shields, if used, must be continuous and insulated from ground, except at the originating panel.
3. Class A and Class X network data requires one pair of wires connecting the last node to the first node.
4. Class A and Class X audio data requires two pairs of wires running in opposite directions, originating at the node containing the ASU.





LIFE SAFETY & INCIDENT MANAGEMENT

Contact us...

Email: edwards.fire@fs.utc.com
 Web: edwards-fire.com

1016 Corporate Park Drive
 Mebane, NC 27302

EDWARDS is a registered mark in the United States and other countries.

© 2018 United Technologies Corporation. All rights reserved.

Specifications

3-CPU3

Agency Listings	UL, ULC, CSFM, CE, LPCB EN54*.
Mounting	2 - Left most local rail spaces
Terminal Size	18-12 AWG (1.0mm ² to 2.5mm ²)
Standby Current	155 mA
Alarm Current	165 mA
Contact Ratings	Nonbypassable Alarm, Supervisory and Trouble Form 'C' 1A at 30 Vdc
Data Down Loading	RJ14 Jack
Operating Environment	0°C - 49°C (32° F - 120° F); 93% at 40° C Non-Condensing

*For EN 54-2: 1997 + A1: 2006, EN 54-4: 1997 + A1: 2002 + A2: 2006, and EN 54-16: 2008 compliant product add suffix -E to model eg. 3-CPU3-E.

Note: CPU current includes the main power supply, since the CPU and PPS cannot be measured separately.

Option Cards

Catalog number	3-RS232	3-RS485A	3-RS485B
Standby Current	58 mA	98 mA	98 mA
Alarm Current	58 mA	98 mA	98 mA
Communication Ports	Two optically isolated RS-232	Three RS-485 Class A or Class X	One Class A or Class X network data circuit and one Class B audio data circuit
Agency Listings	UL, ULC, CSFM, CE, LPCB, EN54*.		
Mounting	Back of 3-CPU3		
Operating Environment	0° C - 49° C (32° F - 120° F); 93% at 40° C Non-Condensing		

*For EN 54-2: 1997 + A1: 2006, EN 54-4: 1997 + A1: 2002 + A2: 2006, and EN 54-16: 2008 compliant product add suffix -E to model eg. 3-RS485A-E

Ordering Information

Catalog Number	Description	Ship Wt. lb (kg)
3-CPU3	Central Processor Unit Module. Add suffix "-E" for EN54 compliant versions.	0.7lb (0.32kg)
3-RS485A	Network Communications Card, Class A or Class X . Add suffix "-E" for EN54 compliant versions .	0.33lb (0.15kg)
3-RS485B	One Class A,X/B network data circuit and one Class B audio data circuit. Add suffix "-E" for EN54 compliant versions.	0.33lb (0.15kg)
3-RS232	RS-232 Communication Card. Add suffix "-E" for EN54 compliant versions.	0.33lb (0.15kg)
3-CPUDR	CPU doors with filler plates. Order separately, one required per CPU where no LCD display is installed.	0.25lb (0.11kg)

