

Overview

The 3-CPU3 is the Central Processing Unit Module monitoring the status of all modules and providing the link for network communications. Although each local rail card contains their own microprocessor, the 3-CPU3 provides all inter-module communication and has the ability to download rail module operating parameters. Upon power up the 3-CPU3 automatically learns all local rail module attributes and locations. Site specific software is loaded into the 3-CPU3 which then downloads data to each local rail module. Firmware upgrades are also done from the 3-CPU3 eliminating the need to unplug chips on rail modules. Internal rail communications is accomplished in a broadcast protocol for fast response.

Mounting must be in the first two local rail spaces. Options for the 3-CPU3 include the addition of an LCD display and User Interface, RS-232 Communication Card, and RS-485 Series Network Communication Cards.

The 3-CPU3 is fully compatible with the 3-CPU and 3-CPU1 modules.

Standard Features

- 16 bit processor
- Up to 1,000 history events
- RS-485 local rail communications
- Multiplexed audio channels
- Network communication RS-485
- RS-232 communication card
- Form 'C' contacts for: Alarm, Supervisory and Trouble
- Low voltage memory write protection
- Non-volatile memory

EST3 Central Processor Unit

3-CPU3, 3-RS485A, 3-RS485B, 3-RS232

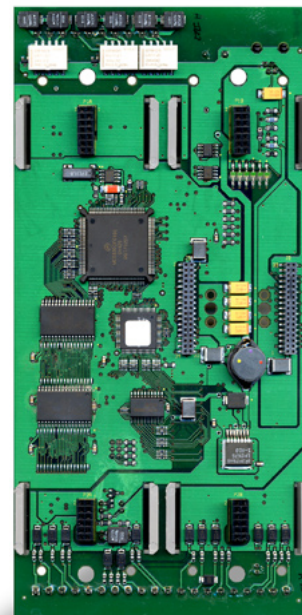

EN54-2:1997+A1 and
EN54-4:1997+A1:2002+A2
pending.



Application

The 3-CPU3 helps make EST3 an extremely powerful and flexible system. As a single node, stand alone system a single 3-CPU3 controls 1 to 19 local rail modules. For larger systems, up to 64 nodes interconnect on a peer-to-peer multi-priority token ring protocol network.

The 3-CPU3 controls all local panel responses to automatic, user initiated, or network reported events. As a network node, it is an equal among peers, there is no master on the network. This gives exceptional response times over the network, less than three seconds.

Each 3-CPU3 provides slots at the back for mounting Network, and RS-232, cards. Removable terminal blocks on the 3-CPU3 support connection of network and audio data wiring. On board common relays also terminate at the 3-CPU3 terminals. To aid in trouble shooting and service, status LEDs monitor local rail, network, RS232 and audio data communications.

The **Network Communications** card mounts to the back of the Central Processor Unit. The 3-RS485A card provides a Class A (Style 7) or Class B (Style 4) circuit for network communications signals and two additional Class A (Style 7) circuits for the digitized audio signals. The 3-RS485B card provides a Class B (Style 4) or Class A (Style 7) circuit for network communications signals and a second Class B (Style 4) circuit for the digitized audio signals. Network messages received by the Network Communications card are re-transmitted to the next network node. Re-transmission maximizes the wire run lengths between nodes. With 64 nodes miles of network length is possible. Fail safe mechanisms built into the card direct connect the data input and output ports should the network card or its related Central Processor fail. Network communications may be configured via copper or fiber media using the 3-FIBMB.

The **3-RS232 Communication Card** mounts to the back of the 3-CPU3. The 3-RS232 has two optically isolated RS-232 ports. The ports support connection of a printer and/or an external command center. Entire network downloading from one location (to all 64 nodes) is available through the RS-232 card.

Engineering Specification

It must be possible to support a single stand alone node or up to 64 nodes communicating on a peer-to-peer token ring protocol network. Network and digitized audio wiring shall be run in a [choose one: Class A (Style 7) or Class B (Style 4)] configuration. Network alarm response from alarm input to signal activation must be under 3 seconds. All field wiring must be to removable terminal blocks. Status LEDs must be provided for communications of network and internal rail communications. Inter-node communication speed must be programmable. Internal rail communications speed must be programmable.

Installation and Mounting

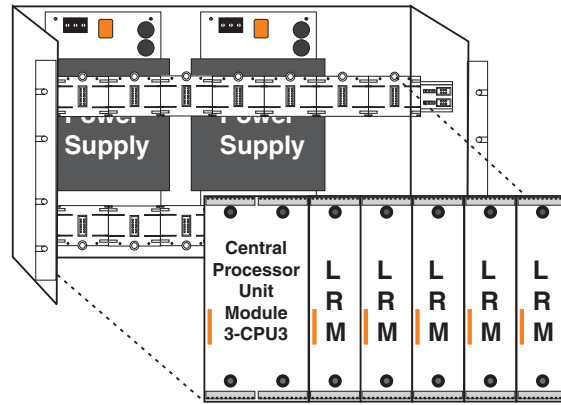

Data

Maximum resistance between any 3 panels	90 Ohms
Maximum capacitance between any 3 panels	0.3 μ F
Maximum distance between any 3 panels	5,000 ft. (1,524 m)

Capacitance, entire network

Maximum Accumulative Capacitance

Wire Size	38.4K Baud	19.2K Baud
18 AWG	1.4 μ F	2.8 μ F
16 AWG	1.8 μ F	3.6 μ F
14 AWG	2.1 μ F	4.2 μ F

Audio

Maximum resistance between any 3 panels	90 Ohms
Maximum capacitance between any 3 panels	0.09 μ F
Maximum distance between any 3 panels	5,000 ft. (1,524 m)

Typical Wiring

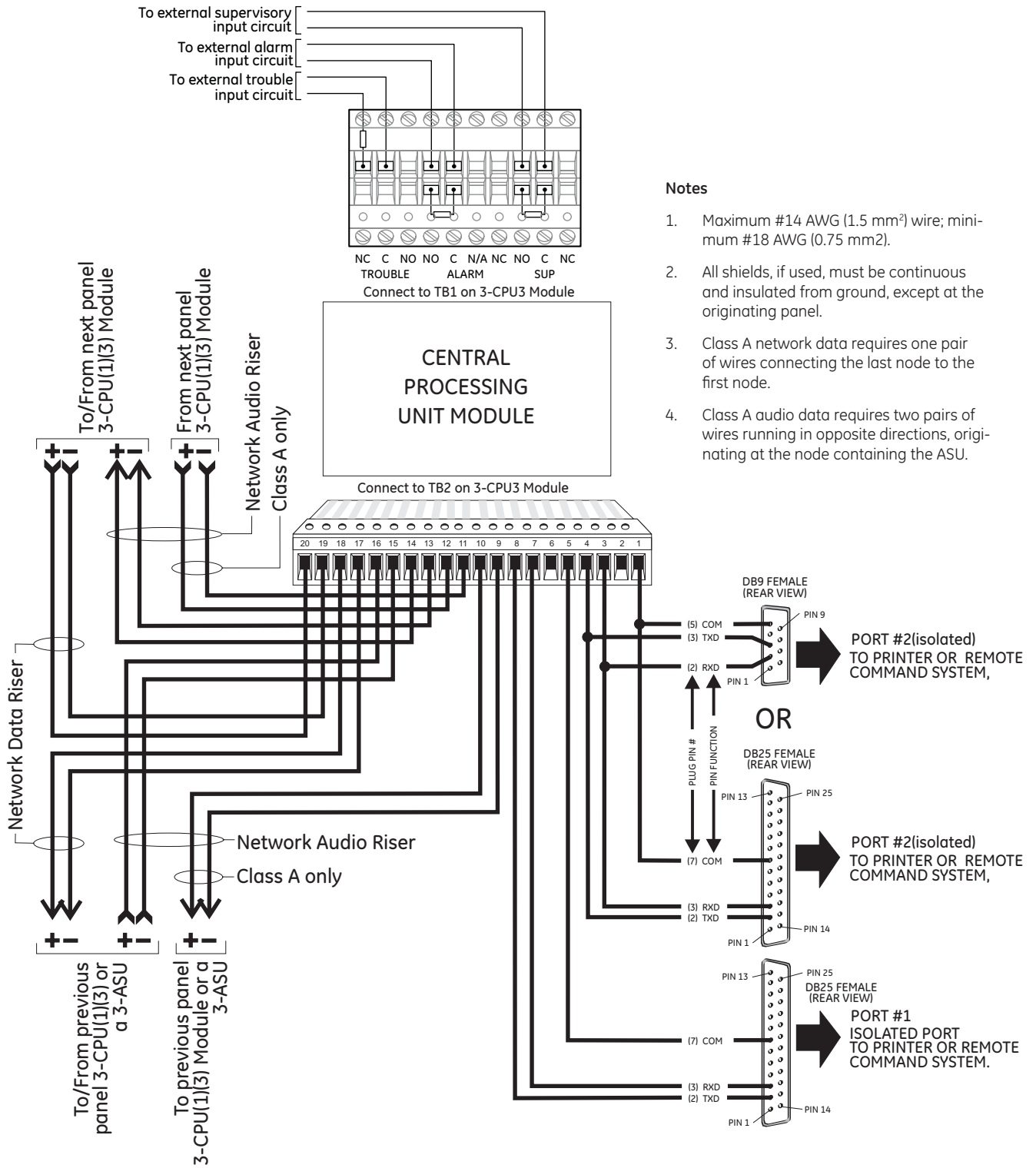

Notes

1. Maximum #14 AWG (1.5 mm²) wire; minimum #18 AWG (0.75 mm²).
2. All shields, if used, must be continuous and insulated from ground, except at the originating panel.
3. Class A network data requires one pair of wires connecting the last node to the first node.
4. Class A audio data requires two pairs of wires running in opposite directions, originating at the node containing the ASU.

U.S.
T 888-378-2329
F 866-503-3996

Canada
T 519 376 2430
F 519 376 7258

Asia
T 852 2907 8108
F 852 2142 5063

Australia
T 61 3 9259 4700
F 61 3 9259 4799

Europe
T 32 2 725 11 20
F 32 2 721 86 13

Latin America
T 305 593 4301
F 305 593 4300

www.gesecurity.com/est

© 2008 General Electric Company
All Rights Reserved

Specifications

3-CPU3

Agency Listings	UL, ULC, CSFM, CE, LPCB EN54* pending.
Mounting	2 - Left most local rail spaces
Terminal Size	18-12 AWG (1.0mm ² to 2.5mm ²)
Standby Current	145 mA
Alarm Current	155 mA
Contact Ratings	Nonbypassable Alarm, Supervisory and Trouble Form 'C' 1A at 30 Vdc
Data Down Loading	RJ45 Jack
Operating Environment	0°C - 49°C (32° F - 120° F); 93% at 40° C Non-Condensing

*EN54-2:1997+A1 and EN54-4:1997+A1:2002+A2 pending

Note: CPU current includes the main power supply, since the CPU and PPS cannot be measured separately.

Option Cards

Catalog number	3-RS232	3-RS485A	3-RS485B
Standby Current	58 mA	98 mA	98 mA
Alarm Current	58 mA	98 mA	98 mA
Communication Ports	Two optically isolated RS-232	Three RS-485 Class A (Style 7)	One Class B (Style 4) or Class A (Style 7) network data circuit and one Class B (Style 4) audio data circuit
Agency Listings	UL, ULC, CSFM, CE, LPCB. EN54 pending*.		
Mounting	Back of 3-CPU3		
Operating Environment	0° C - 49° C (32° F - 120° F); 93% at 40° C Non-Condensing		

*EN54-2:1997+A1 and EN54-4:1997+A1:2002+A2 pending

Ordering Information

Catalog Number	Description	Ship Wt. lb (kg)
3-CPU3	Central Processor Unit Module	0.7lb (0.32kg)
3-RS485A	Network Communications Card, Class A (Style 7)	0.33lb (0.15kg)
3-RS485B	One Class A/B network data circuit and one Class B audio data circuit	0.33lb (0.15kg)
3-RS232	RS-232 Communication Card	0.33lb (0.15kg)



imagination at work